



PRIVACYVUE™

Switchable Privacy Glass
An Innovative Product by Dash Door

Dash Door & Glass

8800 NW 23rd Street

Miami, FL 33172

PH: 305.477-1164

FAX: 305.477.2502

Email: info@PrivacyVue.com

www.PrivacyVue.com

www.dashdoor.com

PrivacyVue™ by Dash Door

8800 NW 23rd Street

Miami FL 33172

PH: 305-477-1164

FAX: 305-477-2502

www.PrivacyVue.com

Contents

COMPANY BACKGROUND	3
PRIVACYVUE™ INTRODUCTION	
Development	4
Technology	5
Manufacturing	6
TECHNICAL DATA	7
GLAZING (Section 08800.2)	8
Part 1. General	
1.1. Description	8
1.2. Quality Assurance	9
1.3. Glazing Personnel	9
1.4. Submittals	10-11
1.5. Product Handling	11
1.6. Warranties	12
Part 2. Products	
2.1. Glass	11-12
2.2. Other Materials	12-13
Part 3. Execution	
3.1. Surface Conditions	13
3.2. Installation	13-14
3.3. Protection	15
3.4. Cleaning	15

Contents (Continued)

APPENDIX I: Glazing Guidelines

1. Setting/Glazing	16
2. Frame Design	17
3. Setting Blocks	17
4. Glass Protection	17

APPENDIX II: Shipping and Receiving

1. Shipping	18
2. Receiving	18
3. Uncrating	18-19
4. Storage	19
5. Unexpected Breakage	19

APPENDIX III: Electrical Installation

1. Supplies Needed	20
2. Wiring	20

APPENDIX IV: Troubleshooting 21

APPENDIX V: Features and Benefits 22

APPENDIX VI: Glass Wall Sample 23

APPENDIX VII: Clarity Standards 24-25

APPENDIX VIII: Shop Drawing Samples 26-27

APPENDIX IX: Architectural Specification Sample 28

APPENDIX X: Haze Factor Specification and Considerations 29

Warranty Certificate 30

PrivacyVue™ by Dash Door

8800 NW 23rd Street

Miami FL 33172

PH: 305-477-1164

FAX: 305-477-2502

www.PrivacyVue.com

Company

- COMPANY:** Dash Door & Closer Service, Inc.
- FOUNDED:** 1955
- LOCATION:** Miami, Florida (U.S.A.)
- BUSINESS:**
- Independent automatic / manual door, contract hardware, glass & glazing, access control - installation, distribution and service center
 - Multi-licensed specialty contractor
 - Specialty product development
- MAJOR PRODUCTS:** visit www.dashdoor.com for all major brands and product lines

PrivacyVue™ by Dash Door

8800 NW 23rd Street
Miami FL 33172

PH: 305-477-1164
FAX: 305-477-2502
www.PrivacyVue.com

PrivacyVue™

FILM MANUFACTURER DEVELOPMENT:

- Obtained license from Kent State University in 1988
- Developed reliable formulations and processes
- Designed its own equipment for production
- Commercialized PDLC film in 1990
- Commercialized PDLC glass in 1994
- Low Haze version in 2005
- Wide Angle version in 2007
- Low Voltage version and new PDLC (U.S. Patent Held)

PRODUCT TYPE:

PrivacyVue™ PDLC switchable privacy glass

APPLICATIONS:

Through PrivacyVue™, you will see things in a whole new light! At the flip of an electrical switch, PrivacyVue™ becomes transparent from a cloudy-white translucent state.

PrivacyVue™ provides creative design for architects and other technical applications.

- Bathrooms/Shower enclosures
- Clinics
- Conference rooms
- Hospital (nurseries, emergency rooms, ICUs, operation rooms)
- Hurricane resistant windows
- Optical shutters
- Projection displays (REAR PROJECTION ONLY)
- Residential Enclosures
- Security windows
- Skylights

PrivacyVue™ by Dash Door

8800 NW 23rd Street

Miami FL 33172

PH: 305-477-1164

FAX: 305-477-2502

www.PrivacyVue.com

Technology

PRINCIPLE:

When the power is off, the liquid crystal molecules are randomly oriented that scatters incident light and PrivacyVue™ becomes opaque.

When electricity is applied, the liquid crystal molecules line up, the incident light passes through, and PrivacyVue™ looks clear.

PDLC Light Scattering Mechanism

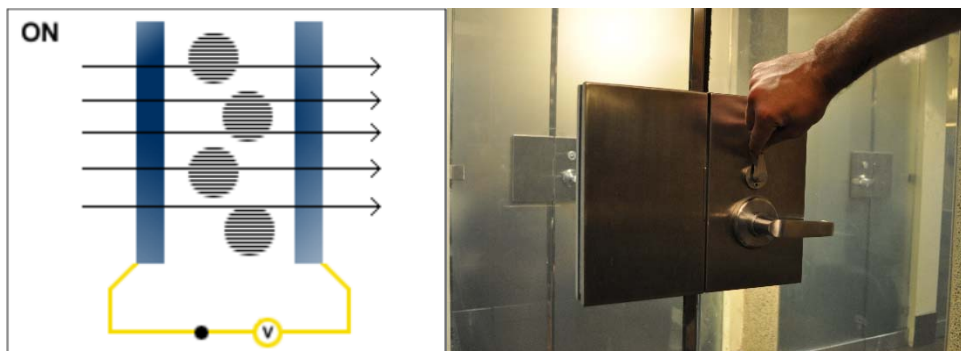
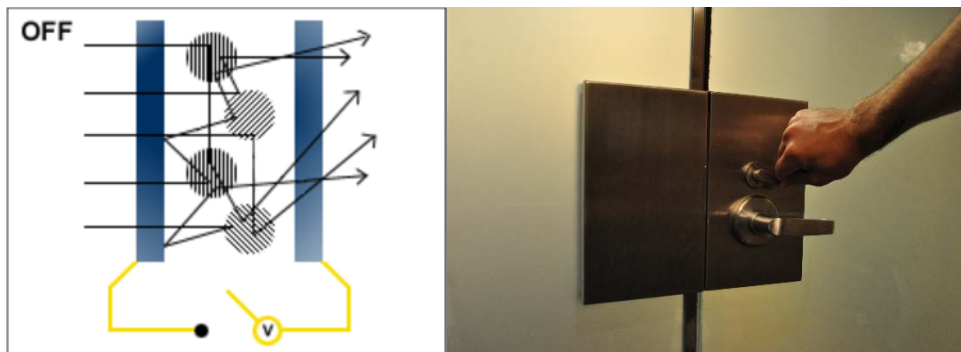

PrivacyVue™ by Dash Door

8800 NW 23rd Street

Miami FL 33172

PH: 305-477-1164

FAX: 305-477-2502

www.PrivacyVue.com

Manufacturing

PrivacyVue™ switchable privacy PDLC film is manufactured in the United States.

The PrivacyVue™ Privacy Film is made of two layers of transparent conductive films sandwiched with PDLC material. The film is then laminated between two pieces of glass. When electricity is applied to the film the liquid crystals line up and the window is clear. When the power is turned off, the liquid crystals return to their normal scattering positions and turn the glass from clear to translucent.

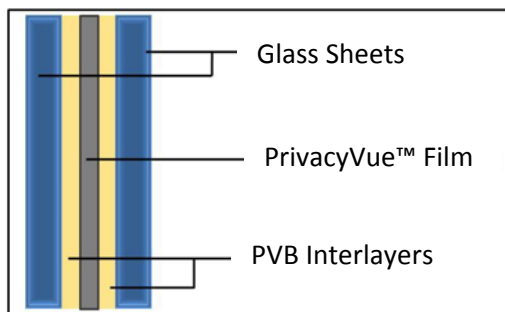

The liquid crystal privacy glass is constructed in a way similar to the construction of laminated glass. The outside skins are made up of glass (normally 5 or 6 mm annealed glass) each side, then a PVB interlayer is inserted on each side to trap and hold the liquid crystal privacy film.

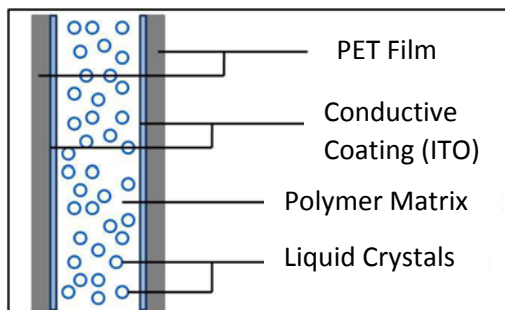

The liquid crystal privacy film is made up of electrically conductive coatings, a polymer matrix and liquid crystals. This film has electrical wiring to be connected to a transformer to supply power for the "on" (clear state) mode.

PrivacyVue™ by Dash Door

8800 NW 23rd Street
Miami FL 33172

PH: 305-477-1164
FAX: 305-477-2502
www.PrivacyVue.com

Technical Data: PrivacyVue™ Privacy Glass

GLASS COLOR: Clear, low-iron “Starphire”, bronze, gray, green tint

GLASS TYPE: Annealed, heat/chemical strengthened, tempered
(All laminated)

THICKNESS:

Interior	5/16" (8 mm) or 7/16" (11 mm)
Door	9/16" (14 mm)
Exterior	1" (25mm) insulating glass unit (3/16" tempered outer glass + 3/8" airspace + 7/16" clear laminated PrivacyVue™ glass)

SIZE (max):

Glass:	Up to 60" x 120" (1,524 mm x 3,048 mm)
Film:	58" x 120" (1,473 mm x 3,048 mm)

SHAPE: Any shape, including holes anywhere

ENVIRONMENTAL:

Storage	-20 °C to 70 °C (-4 °F to 158 °F)
Operation	-10 °C to 60 °C (14 °F to 140 °F)

ELECTRICAL:

Driving voltage	65 ± 5 volts A.C.
Current	less than 20 mA/ft ² (215 mA/m ²)
Power	less than 0.5 W/ft ² (5 W/m ²)

SWITCHING TIME: Approx. 100 milliseconds at room temperature

OPTICAL:

Transmission (visible)	approx. 75%
View angle	approx. 150°
Scattering effectiveness	approx. 1 inch

LIFE: Greater than 10 years (indoors) (when used, installed, and stored properly per the usage, storage and installation specifications referenced herein).
Claim is supported by manufacturer’s testing data

Glazing (Section 08800.2)

PART 1 - GENERAL

1.1 DESCRIPTION

- A. Work included: Provide specialty glazing and glazing accessories where shown on the drawings, as specified herein, and as needed for a complete and proper installation.

- B. Related work:
 - 1. Documents affecting work of this section include, but not necessarily limited to General Conditions, Supplementary Conditions, and Sections in Division 1 of these specifications. Please select appropriate sections.
 - 2. Section 08410: Aluminium Entrances and Storefronts
 - 3. Section 08300: Glass Doors
 - 4. Section 08425: Automatic Entrance Doors
 - 5. Section 08960: Sloped Glazing
 - 6. Section 09875: Structural Sealant Glazing System
 - 7. Section 07920: Sealants
 - 8. Section 16050: Electrical
 - 9. Section 08600: Wood Framing Applications
 - 10. Section 08210: Wood Doors
 - 11. Section 08100: Metal Doors & Frames
 - 12. Section 08510: Steel Windows (Hollow Metal)

Glazing (Section 08800.2)

1.2 QUALITY ASSURANCE

A. PrivacyVue™ panels comply with the following:

1. Standards

- a. FGMA (Flat Glass Marketing Association)
- b. IGMA (Insulated Glass Manufacturers Association)

2. Certification/Ratings

a. Safety Glazing

- 1. CPSC (Consumer Products Safety Commission)
16 CFR 1201 Cat II
- 2. ANSI (American National Standards Institute) Z97.1-2004
ANSI SAE Z26.1-1996 (safety glazing for motor vehicles)

b. Sound Control

- 1. ASTM International (American Society for Testing and Materials)
E90-83 (sound transmission class), E90-87 (analysis)
- 2. E413-87 (certification)

PrivacyVue™ Panel Sound Control Data

Overall Thickness	Construction	STC Value
5/16" (8mm)	1/8" x 0.060 x 1/8"	35
7/16" (11mm)	3/16" x 0.060 x 3/16"	37
9/16" (14mm)	1/4" x 0.060 x 1/4"	39
1" (25mm)	3/16" x 1/2" airspace x 5/16" laminate	39

Sound Transmission Control (STC): 15–25 = poor; 26–35 = marginal;
36–45 = good; 45–55 = very good; 56 or higher = excellent

Glazing (Section 08800.2)

1.2 QUALITY ASSURANCE (continued)

3. Others

IGCC (Insulated Glass Certification Council) #681 per ASTM guidelines set forth in E-773 and certified to level CBA

ASTM C-920 (elastomeric joint sealants)

ASTM C-162 (standard terminology of glass and glass products)

ASTM C-1036 (flat glass)

ASTM C-1048 (heat-treated flat glass)

ASTM C-1172 (laminated architectural flat glass)

ASTM C-1422 (chemically-strengthened flat glass)

ASTM C-1464 (bent glass)

ASTM D1003 (haze and luminous transmittance of transparent plastics)

ASTM E2190 (specification for insulating glass units)

ASTM E2188 (accelerated weathering)

ASTM E2189 (fog resistance)

ASTM F-1637 (standard practice for safe walking surfaces)

ASTM F-1646 (terminology relating to safety and traction for footwear)

4. These quality assurance provisions should be read in conjunction with the attached limited warranty. Dash Door's obligations with respect to replacement of PrivacyVue™ panels are limited to the terms set forth in the attached limited warranty and any conflict between the quality assurance guidelines herein and the limited warranty attached hereto shall be resolved in favor of the latter.

1.3 GLAZING PERSONNEL

Use adequate numbers of skilled workmen who are thoroughly trained and experienced in the necessary crafts and who are completely familiar with the specified requirements and the methods needed for proper performance of the work of these Sections.

1.4 SUBMITTALS

A. Comply with pertinent provisions of Section 01340.

B. Product data: Within 60 calendar days after the Contractor has received the Owner's Notice to Proceed, submit:

1. Materials list of items proposed to be provided under this Section.
2. Manufacturer's specifications and other data needed to prove compliance with the specified requirements.

Glazing (Section 08800.2)

1.4 SUBMITTALS (continued)

3. Manufacturer's recommended installation procedures which, when approved by the Architect, will become the basis for accepting or rejecting actual installation procedures used on the work.

- C. Samples: Accompanying the above product data, submit:
 1. Samples of each type of gasket proposed to be used.
 2. Samples of each type of sealant proposed to be used, tested for each substrate involved (ADD-certified by sealant supplier if organic coating involved) proving compliance with manufacturer's recommended sealants for use with specialty glass.

1.5 PRODUCT HANDLING

- A. Comply with pertinent provisions of section 01640. Refer to Section 1.2 Quality Assurance for the Applicable ASTM standards for proper laminated glass handling.

- B. Follow Strict glass handling and storage recommendations of referenced standards, Including any special instructions from the specialty glass manufacturer. Refer to Appendix II, 4A, for the manufacturer's recommendations.

1.6 WARRANTIES

See warranty at the end of this binder.

PART 2 – PRODUCTS

2.1 GLASS

- A. General
 1. All glass complies with ASTM C-106-06.
 2. Provide the type and thickness shown on the Drawings or specified herein.
 3. Where type or thickness, or both are not shown on the Drawings or as specified herein, provide type and thickness directed by the Architect.
 4. PrivacyVue™ panel WILL NOT be given a permanently etched safety certification label unless specifically directed by the Architect.
- B. Float glass-clear: Type 1, Glass 1, Quality q3.
- C. Heat Absorbing glass: Type 1, Class 2, Quality q5.

Glazing (Section 08800.2)

- D. Tempered glass: Comply with ASTM C-1048-85 and Z976.1-84.
- E. Laminated Glass:
 - 1. Provide specialty clear and/or tinted consisting of an outerface and inner face of q5 float glass laminated under heat and pressure to a liquid crystal film, a proprietary product PrivacyVue™ by Dash Door & Closer Service, Inc., Miami, FL (305) 477-1164, fax (305) 477-2502.
 - 2. PrivacyVue™ panels with widths exceeding maximum width of 60" (contact a PrivacyVue™ representative for these larger dimensions) will be manufactured with two butt-jointed liquid crystal films laminated into a single Panel.
 - 3. Alternative Butt Joint Applications – See Section 2.2 B.1.a
 - 4. PrivacyVue™ Glass Optical performance – See page 8 Technical Data.
 - 5. Glass used: PrivacyVue™ can be annealed, heat strengthened, or tempered.

2.2 OTHER MATERIALS

A. Special Electrical Conditions

- 1. For all fixed panel installation, a separate PrivacyVue™ AC Adapter shall be provided for each 60 square feet or fraction thereof. Power source of 110 VAC, 60 Hz electricity must be supplied from a GFI circuit or equivalent standard breaker (see 1.1. on p.21). The AC Adapter should be connected to an accessible standard double junction box connected to ground continuity.
- 2. For all swing Panel installations, the AC Adapter should be located near the hinge side of door/window jamb and all installation is to conform to manufacturer's instructions.

B. Special Glazing Requirements

- 1. Interior Butt Glazing
 - a. PrivacyVue™ panels can be butt glazed using a recommended minimum 7/16" thickness panel.
 - b. A standard neutral cure structural silicone sealant may be used to close the joint. A minimum of a ¼" separation between panels is recommended.
 - c. Refer to applicable local building codes for design load requirements regarding interior glazing.

Glazing (Section 08800.2)

2.2 OTHER MATERIALS (continued)

2. Swing Doors/Windows
 - a. Swing door/window units may be glazed with PrivacyVue™ panels.
 - b. Door package will be complete with door header, door leaf, power transfer device, and all other hardware. Finish, cladding, hardware and keying may be selected as options.
 - c. Window Package will be complete with sash, frame, power transfer device and all hardware. Finish cladding and hardware may be selected as options.
- C. Provide other material, not specifically described but required for a complete and proper installation, as specified or selected by the Contractor subject to the approval of the Architect.

PART 3 – EXECUTION

3.1 SURFACE CONDITIONS

- A. The purchaser must examine the areas and conditions under which work of this Section will be performed. Correct conditions are critical to the timely and proper completion of this work. Do not proceed until unsatisfactory conditions are corrected. Refer to 'ASTM Glass and Glazing Standards for the Building Industry' for the applicable and satisfactory conditions.
- B. After preparation of the glazing system, clean glazing channels, stops and rabbets to receive the glazing materials, making free from obstructions and deleterious substances which might impair the work.
 1. Remove protective coating which might fall in adhesion or interfere with bond of sealants.
 2. Comply with manufacturers' instructions for final wiping of surfaces immediately prior to application of primer and glazing compounds or tapes. USE ONLY NEUTRAL CURE SILICONES. **DO NOT USE ACETIC SILICONES.**

3.2 INSTALLATION

- A. Inspect each piece of glass immediately prior to start of installation.
 1. Do not install items which are improperly sized, have damaged edges, or are scratched, abraded, or deficient in any other manner.

Glazing (Section 08800.2)

3.2 INSTALLATION (continued)

2. Do not remove labels that were provided by the glass supplier from the glass until so directed by the Architect.
 3. Adhere to all PrivacyVue™ installation instructions and installation drawings (for a sample wall installation, see Appendix VII on P. 30). For multi-panel wiring instructions, see Shop Drawing on p. 32.
- B. Locate sill setting blocks of standard width and thickness at quarter points of all glass lights unless otherwise recommended by manufacturer or supplier.
1. Use blocks of proper durometer, size and thickness to support the glass in accordance with the manufacturer's recommendations.
 2. Glass lap and edge clearances must be provided according to pertinent codes and standards of manufacturer's.
- C. Set Glass in a manner which produces the greatest possible degree of uniformity in appearance.
1. Installation of the glass in dynamic frames such as operable windows or sliding doors must meet architectural specifications.
 2. Glazing to the exterior and wet interior conditions must be wet-sealed and impervious to moisture with provisions to allow for weeping of condensation that may infiltrate the system.
 3. Pressure glazing systems without positive positioning stops are not to be used with this glass.
 4. Glazier has to place electrical connections properly to allow access by an electrician.
 5. Electrical connections must exit at the head condition of any framing system using PrivacyVue™ panels in wet environment applications.
- D. Cut and seal the joints of glazing gaskets in accordance with the manufacturers' recommendations, provide watertight and airtight seal at corners and other locations where joints are required.
- E. The terms of the limited warranty attached thereto hereto are applicable to the extent that proper installation techniques are utilized.

PrivacyVue™ by Dash Door

8800 NW 23rd Street
Miami FL 33172

PH: 305-477-1164
FAX: 305-477-2502
www.PrivacyVue.com

Glazing (Section 08800.2)

3.3 PROTECTION

Protect glass from breakage after installation by promptly installing streamers of ribbons, suitably attached to the framing and held free from the glass. Do not apply warning markings, streamers, ribbons, or other items directly to the glass except as specifically directed by the Architect.

Note: Windblown objects, welding sparks, or the material applied to the glass surface during construction may cause irreversible damage.

3.4 CLEANING

Cleaning of the glass during the subsequent weathering period is necessary. Abrasive cleaners should never be used, particularly when the surface to be cleaned has a reflective coating. Clean the Panels with mild soap or very weak acid (vinegar) applied with a soft, clean, grit-free cloth. The glass and framing should be rinsed immediately with water and the excess should be squeezed away from glass, taking care not to contact the glass with any metal parts. The framing should be wiped dry.

Appendix I: Glazing Guidelines

1. SETTING/GLAZING

PrivacyVue™ panels may be oriented in any direction. The Flat Glass Marketing Association (FGMA) Glazing Guidelines are to be followed except as noted.

Glazing Methods:

A. Interior Applications – Laminated PrivacyVue™ panels

Dry Glazing: This is preferred interior glazing method.

Wet Glazing: If an elastomeric (non-acetic) sealant is used, it must be compatible with the panel's polyvinyl butyral (PVB) interlayer. Never use putty or glazing compound to glaze a PrivacyVue™. Refer to the FGMA Glazing Manual for further information.

B. Exterior Applications – Insulated Glass Units made with PrivacyVue™

Wet Glazing: Pre-shimmed glazing tape and non-acetic sealants are required to create a seal impervious to moisture for all applications.

C. Butt-Joint Glazing: PrivacyVue™ panels can only be butt-joint glazed in interior applications.

D. Non-Acetic Sealants: The following sealants are listed as non-acetic by their manufacturers. Confirm with these manufacturers the compatibility of their respective sealants with regard to butt-joint glazing PrivacyVue™ panels (a PVB laminated flat glass product).

- GE SSG4000
- Dow Corning 399, 795, 991, 995, 1199
- Rhodorsil 3B (Rhone-Poulenc)
- Schnee-Morehead SM5731

E. Structural Silicone Glazing: Insulated glass units manufactured with PrivacyVue™ panels should NOT be structurally silicone glazed.

Appendix I: Glazing Guidelines (Continued)

2. FRAME DESIGN

Standard FGMA frame edge clearance and face clearances may be used, EXCEPT edge bite must be 7/16" minimum and framing must have a hole of ¼" diameter. To maintain a proper seal against the infiltration of water and air, adequate bite is required.

Inadequate clearance for the edges can cause damage due to glass-to-metal contact. The FGMA Information Chart shows minimum edge clearances with a tolerance of $\pm 1/16"$. This should only be increased if the surrounding materials' tolerances are different to control. See SCD 23300 or SCD 23200. Refer to FGMA Glazing Manual details.

The industry standard for framing deflection must be adhered to. The deflection must not exceed either the length of the span divided by 175, or 3/4", whichever is less. All expansion joints and anchors must be designed so that the glass framing does not incur a load due to structural movement. Refer to the FGMA Glazing Manual for the details of adequate framing systems.

3. SETTING BLOCKS

Glass larger than six (6) square feet should be placed on two EPDM or neoprene setting blocks. These blocks should have a durometer hardness of 85 ± 5 . They should be centered at the bottom quarter points (i.e. equal distance). The blocks should be 1/16" narrower than the channel width. Lock-strip gasket systems also require setting blocks. Recommendations can be obtained from the gasket manufacturers.

4. GLASS PROTECTION

Once the glass is installed, the architect, general contractor, or owner should provide for glass protection and cleaning. Weathering steel such as Cor-Ten or alkaline materials may cause surface damage due to staining. Abrasive cleaners should never be used, particularly when the surface to be cleaned has a reflective coating. Windblown objects, welding sparks, or other material applied to the glass surface during construction may cause irreversible damage.

\

Appendix II: Shipping and Receiving

1. SHIPPING

If no preferred carrier is specified, the Panels for domestic customers will be shipped through our laminator's common ground carrier.

For overseas customers, specifying whether the freight should be shipped via Air or Sea is necessary. Where available, it is recommended to have your own agent to take care of the shipping and custom clearance issues.

Due to the difficulty in estimating the accurate weight and dimensions of the crate at the time of giving a quotation, the Panels will be shipped Freight Collect with the full value insured.

2. RECEIVING

Customers should inspect the shipment in the presence of the freight delivery driver to ensure no damage to the Panels has occurred. It is critical that this inspection take place in the presence of the freight delivery driver. If you fail to inspect the shipment, the carrier and Dash Door & Closer Service, Inc. are not responsible for damages.

Before signing for and accepting the shipment from the carrier, inspect the crate (s) for the following items:

- a. Inspect crate(s) for damage.
- b. Check Tip 'N Tell indicator.

If there are any indications of possible damage, you should immediately, in the presence of the carrier, open the crate(s) and inspect each PrivacyVue™ Panel for damage. If damage to any of the Panels is found, the shipping documents should be so noted and driver's signature obtained as a witness. You should inform Dash Door & Closer Service, Inc. immediately of any damaged Panels. Photographs should be furnished. A freight claim should be filed to the carrier as early as possible.

3. UNCRATING

Keep the crate upright at all times while removing the cover. The crate may be tilted, leaning at 5° - 7° from vertical. To avoid possible damage to the Panels, open the lid side first. All perimeter edge blocking should be carefully loosened and removed so that the Panels don't have to be pried out of the crate. Remove the Panels carefully.

PrivacyVue™ by Dash Door

8800 NW 23rd Street
Miami FL 33172

PH: 305-477-1164
FAX: 305-477-2502
www.PrivacyVue.com

Warning: The loose wires from the Panels are not to be used for lifting, moving or positioning the Panels.

Appendix II: Shipping and Receiving (Continued)

4. STORAGE

Glass edges frequently sustain damage due to careless handling at some point between manufacture and installation. Handle with care! If the glass is to be stored on the job site or in warehouse conditions, proper blocking and protection should be maintained at all times. As with other flat glass products, the PrivacyVue Panels must be stored where the relative humidity is less than 80% to prevent the glass from staining. The glass temperature should be held nearly constant to prevent moisture condensation on the Panels. Storage temperature range is $-4 - 158$ °F ($-20 - 70$ °C). The crate of Panels should be kept in an upright position or tilted at $5^{\circ} - 7^{\circ}$ from vertical at all times using broad, sturdy uprights to support the weight of the crate. The terms of the limited warranty attached hereto are applicable only to the extent that proper storage techniques are utilized.

5. “UNEXPECTED” BREAKAGE

“Unexplained “glass breakage may occur even after all precautions have been taken. Such breakage is beyond the control of the manufacturer and therefore non-warrantable. This includes but is not limited to the following types of breakage or other damage:

- Thermal stress
- Damage during sand blasting
- Glazing system pressures
- Damage during glazing
- Handling and storage problems
- Excessive wind loads
- Objects and debris striking the glass
- Damage by persons/objects at the construction site

Appendix III: Electrical Installation

1. SUPPLIES NEEDED

Installation of PrivacyVue™ panels require the following items:

1. A 15 AMP (minimum) ground fault interrupter circuit breaker with 110 VAC 60 Hz (installer-owner supplied) electricity. For dry applications, a standard circuit breaker with the same above GFI specifications can also be used.
2. A wall mounted switch and /or remote control, 110 VAC 60 Hz (installer/owner supplied). This switch is required to allow the panels to be turned 'ON'.
3. PrivacyVue™ AC Adapter: PrivacyVue™ panels may be connected in parallel up to 60 square feet total area per single PrivacyVue™ AC Adapter.

2. WIRING

1. PrivacyVue™ requires all electrical installations be completed by a licensed electrician, and in compliance with all coding requirements under applicable state or local laws as identified by the licensed electrician.
2. Before installation, inspect bus bars, electrode leads and wires to assure insulation. No exposed bus bars, electrode leads, or wires should contact any metal frames that will damage transformer and PrivacyVue™. Insulating tapes can be used to wrap exposed bus bars, electrode leads, or wires which may be caused during glass lamination or shipping.
3. Multiple PrivacyVue™ panels should be connected parallel with the transformer. Make sure that transformer "IN" connects to 110VAC, and "OUT" connects to PrivacyVue™. The output voltage is ~ 65 VAC. Each transformer controls up to 60 square feet of PrivacyVue™.
4. Before turning on the power, test resistance reading between the metal frame and electrode and make sure that the resistance reading is infinite. Otherwise, check short location and insulate electrodes from metal frames.
5. PrivacyVue™ uses less than one watt per square foot in the "ON" (clear) state. No electricity is consumed in the "OFF" (translucent) state. PrivacyVue™ can be controlled with either a single or multiple switches or a remote controller.

Appendix IV: Troubleshooting

CAUTION: PrivacyVue™ operates at 65 VAC and 60 Hz. Higher voltage and frequency may cause permanent damages.

Troubleshooting and electrical service must be performed by a qualified electrician who has read and understood this document.

Switch the power ON. Verify that the panels turn clear. If one or more PrivacyVue™ panels are not operating:

1. Check the circuit breaker to verify power. If there is no power from the circuit breaker, reset or replace the circuit breaker.
2. Check the wall switch to verify power. If there is no power from the wall switch check the connection or replace the wall switch
3. Check input to the AC Adapter of affected panels to verify power. If there is no input power to the AC Adapter, check the wiring between the wall switch and the AC Adapter.
4. Check output from the AC Adapter of affected panels to verify power. If there is no output power from the AC Adapter, the fuse may have blown. Replace fuse with the same size and specifications which is available at electronic supply stores.

NOTES

1. Use care when opening the AC Adapter and allow a few minutes to cool down. Internal electronic parts may be very hot. This is normal.
2. Warning: Do not substitute a higher fuse rating! Fuse rating is critical to properly protect PrivacyVue™ panels and the AC Adapter.
3. Lighting that is place directly onto the PrivacyVue™ panels may cause a HIGH HAZE effect. It is recommended that direct light be place away from the panels to ensure optimum clarity. See diagram on page 24.

PrivacyVue™ by Dash Door

8800 NW 23rd Street
Miami FL 33172

PH: 305-477-1164
FAX: 305-477-2502
www.PrivacyVue.com

Appendix V: Features and Benefits

UNIQUE FEATURES:

Privacy and security with architectural integrity
Visual Attention to interior and exterior design
No distracting shutters and drapes
Beauty and Functions Combined!

HOW IS PRIVACYVUE™ GREEN?

Saves energy by using natural lighting while maintaining privacy
Environmentally-friendly by:

- Reducing fabric wastes used to make curtain/drapes
- Eliminating the need for projection screens and dry erase boards

Liquid crystal components are organic and biodegradable
Very low power consumption (equivalent to a clock radio)
Blocks over 80% infrared and over 99% ultraviolet light

BENEFITS TO OUR CUSTOMERS

Highest Quality Product:

Leading manufacturer in Liquid Crystal Displays (LCD)
Cooperation with experts in glass and architectural industries

Qualified Laminators in both east and west coasts

Lower shipping costs to customers

Customer Services and Technical Support

Quick response to customers' needs
Field supervision when necessary

PrivacyVue™ by Dash Door

8800 NW 23rd Street

Miami FL 33172

PH: 305-477-1164

FAX: 305-477-2502

www.PrivacyVue.com

Appendix VI: Glass Wall Sample

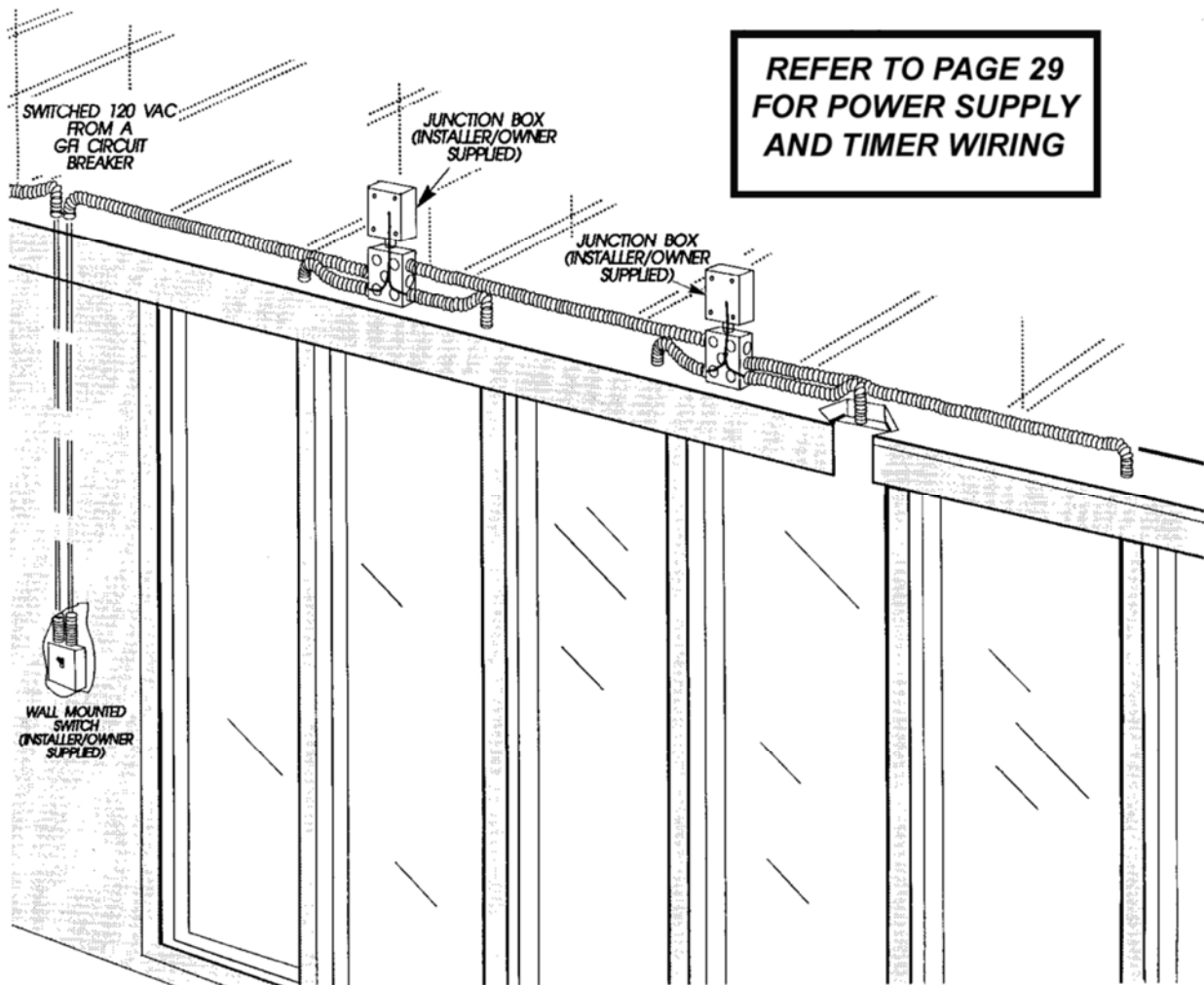

NOTE: This is a representation of one way to wire the panels.

Please refer to your local code for variations.

NOTE: It is recommended to place lighting away from the panels.
See photos and descriptions on page 26.

Appendix VII: Clarity Standards

CLARITY STANDARDS – all photos were taken at the same distance and angle for a precise measurement of lighting conditions. **Architects & Designers: NOTE: As demonstrated below consider the placement of any lighting near the privacy glass.**

1 - Worse Lighting Conditions

Lights that are only on the outside of the conference room will cause an imbalance in light intensity. This will increase the haze.



2 - Better Lighting Conditions

Lights on the outside of the conference room are higher in intensity than on the inside. This will result in a slight haze.



Appendix VII: Clarity Standards (Continued)

3- Best Lighting Conditions

Lights on the inside of the conference room and outside are evenly balanced in intensity and sufficiently diffused at appropriate distances.



4- Low Haze in Dark State (all lights OFF)

No lights on the inside or outside of the conference room will result in little haze.



Appendix VIII: Shop Drawing—Single Lite

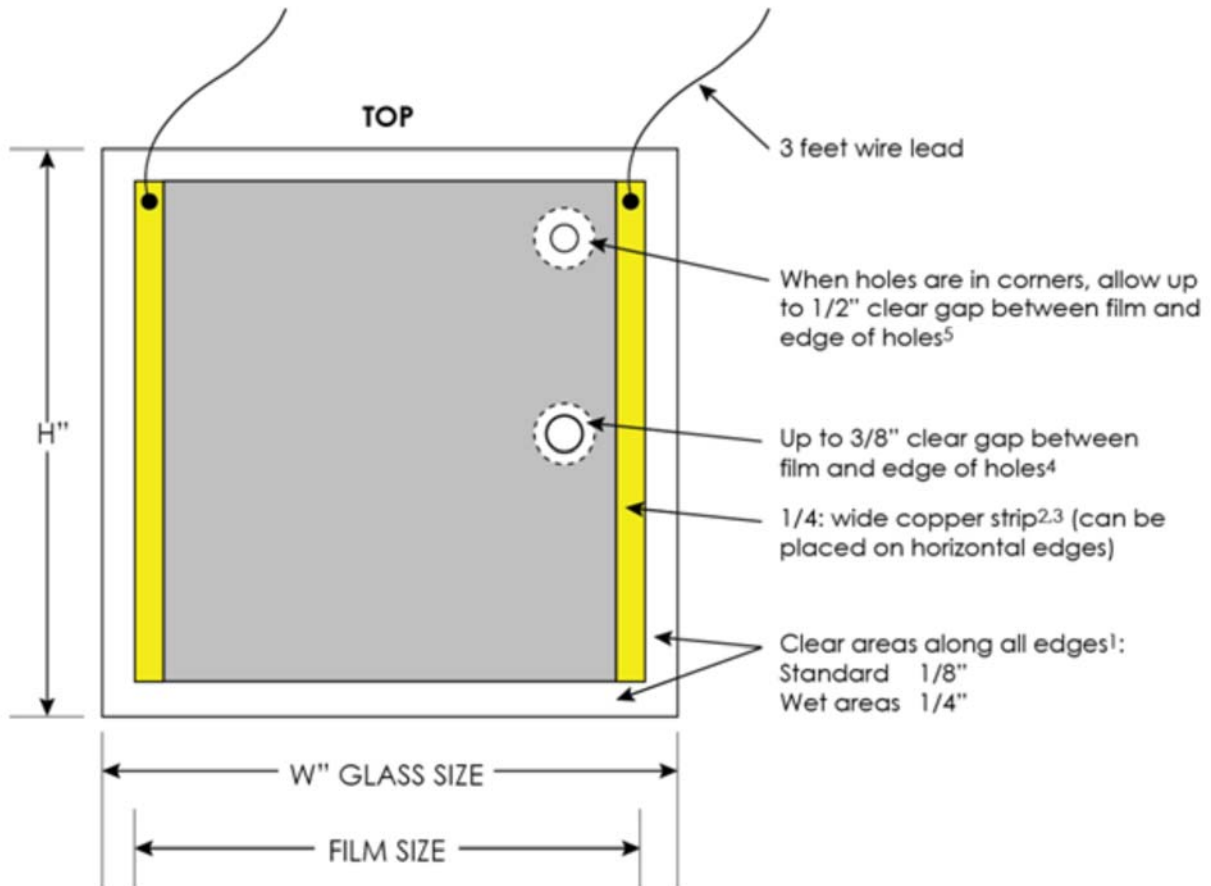

NOTE:

1. There will be about 1/8" clear visible area along all 4 edges. The clear visible area is transparent all the time. For wet areas, visible areas will be 1/4".
2. The width of the busbar (copper strip) is 1/4". The busbar can be placed along long or short edges.
3. Edges where the electrodes are placed (vertical edges in the above drawing) have to be covered by min. 1/2" (3/4" recommended). Cover min. 1/4" for other edges.
4. Off-centered holes will have a displacement of 3/8".
5. Holes in corners are displaced up to 1/2" due to more film shrinkage in corners.

Appendix VIII: Shop Drawing – Multiple (or Butt-Joined) Lites

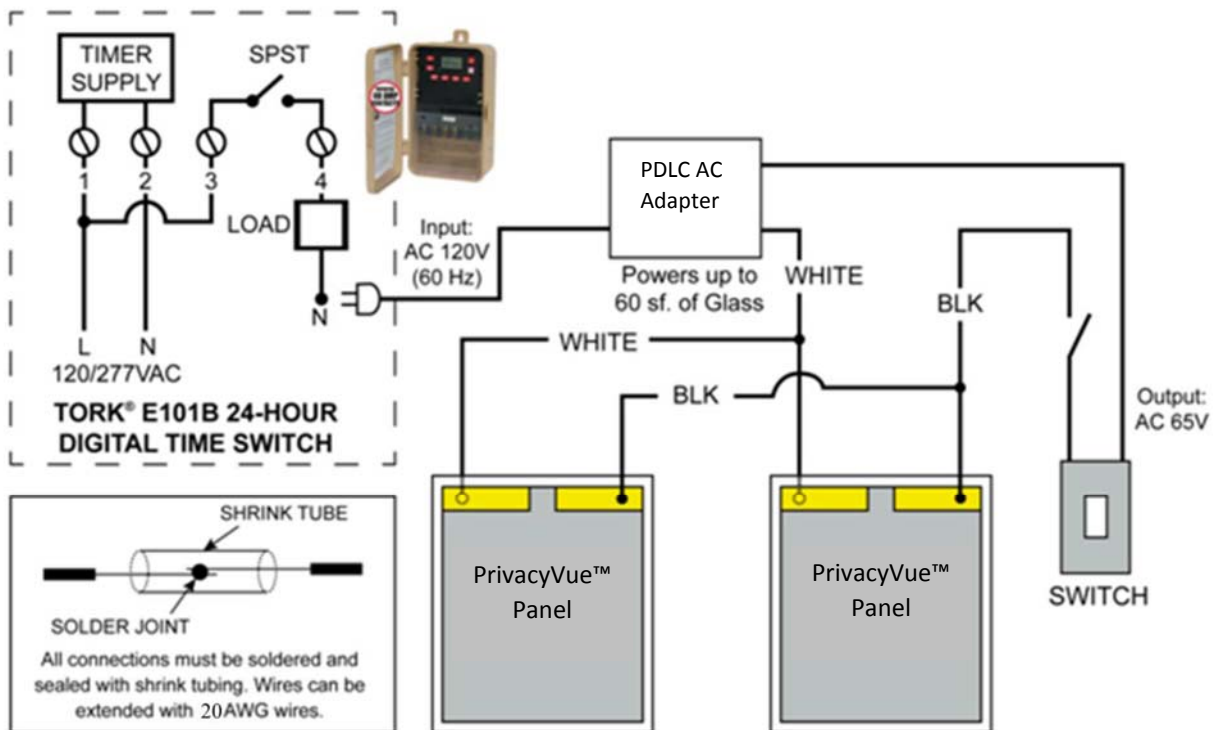

NOTES:

1. There will be ~ 1/2" of clear, visible areas when panels are butt joined. The clear areas can be covered by artificial grid, tape, or other decorative material as desired to provide complete privacy.
2. Exterior switches can be wired between the AC Adapter and panels as desired. Wire extensions must be 20 gauge minimum.
3. Each AC Adapter is only capable of supporting up to 60 sq. ft. of glass. The example connection diagram above shows the maximum width and length per unit.
4. Butt joined using neutral silicone only.

Appendix IX: Architectural Specification Sample

Switchable Privacy Glass:

- A. Laminated glass assembly for clear glass panes with polyvinyl butyral (PVB) films which are 0.76 mm (0.030 inch) thick on each side. Polymer-dispersed liquid crystal film (PDLC) core having electrical connections.
 - 1. With voltage PDLC core becomes transparent.
 - 2. Without voltage PDLC core becomes translucent.

- B. Electric Connections:
 - 1. Locate steel channel cap on one panel edge, integrally connected to glass panel.
 - 2. Integrally connect flexible steel conduit, not less than 1800 mm (six feet long), to steel channel cap. Provide threaded and fitting at free end.
 - 3. Integrally connect type TFFN or THHN number 20 AWG minimum size to panel with not less than 150 mm (six inches) extending beyond flexible conduct end.

- C. Power Conditioner:
 - 1. Designed to provide sinusoidal wave electrical power to discharge the LC film, suppress voltage surges and transients, reduces in rush current and reliably discharge the LC film.
 - 2. Operate from 120 volt AC, 60 Hz input.

- D. Switchable privacy glass assembly listed by UL in Building Materials Directory or other approved testing laboratory bearing permanent mark of approval.

- E. Switchable privacy glass:
 - 1. Both panes ASTM C1048, Kind HS, Condition A, Type I, Class 1, Quality q3, 4.8 mm (3/16 inch) thick.
 - 2. Size as indicated.
 - 3. Thickness 7/16”.

- F. Switchable Privacy Glass system meeting the above specifications as provided by Dash Door & Closer Service, Inc., Telephone No. 305-477-1164, Contacts: Steve Sanko and Nick Curci, is acceptable.

Appendix X: Haze Factor Specification and Considerations

%HAZE: 5.0% ± 1.5%
%VLT: approx. 75%

All PrivacyVue™ Film/Glass are rigorously inspected for quality and clarity. Because PrivacyVue™ Film/Glass contains liquid crystal (LC) material, it inherently possesses some level of “haziness” and would not exhibit the same level of clarity as regular float glass. Therefore, it is NOT recommended to butt-joint PrivacyVue™ glass adjacent to regular float glass.

In addition, the inherent haziness is increased at wider viewing angles and with big disparities in light intensities (see diagram below). This phenomenon is normal because PrivacyVue™ Film/Glass is a light diffuser and will change in haze at varying viewing angles and lighting conditions.

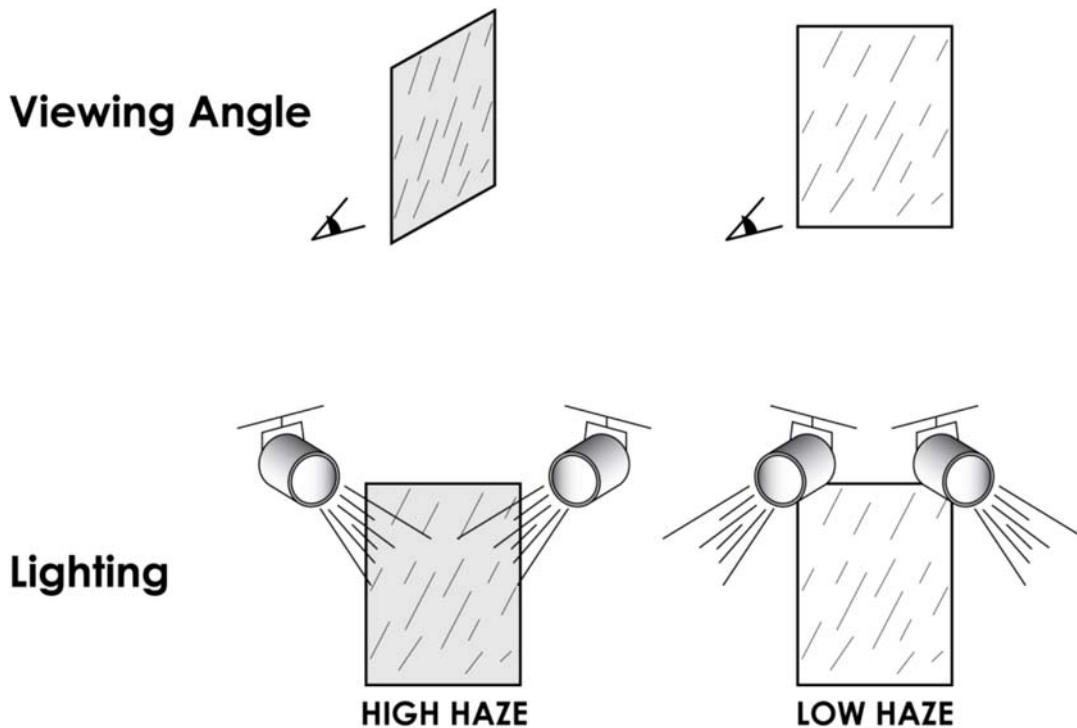

PrivacyVue™ by Dash Door

8800 NW 23rd Street

Miami FL 33172

PH: 305-477-1164

FAX: 305-477-2502

www.PrivacyVue.com

[Project Specific Limited Warranty Certificate - HERE](#)